

OWNER'S MANUAL



 **Polaris380**

IMPORTANT INFORMATION

SERIAL NUMBER

Important Information

- Before installing the Polaris, make sure the pool filter is clean.
- New plumbing lines should be flushed out before installing the Polaris.
- The Polaris should not be used to remove plaster dust in new pools.
- Except when checking the wheel RPM, do not handle the Polaris while it is operating.
- Always remove the Polaris **before swimmers enter the pool**.
- Disconnect the Polaris from the pool wall when cleaning or backwashing the pool filter.
- Always remove the Polaris from the pool before chemical shock treatments.
- After cleaning or backwashing, let the filtration system run for at least five minutes before re-connecting the Polaris.

For customer service or support:

- Please mail Warranty Card immediately.
- For on-line support: www.polarispool.com
- To contact Polaris: **US and Canada**
Customer Service
2620 Commerce Way
Vista, CA 92081-8438
1-800-822-7933

Polaris Vac-Sweep® 380 Limited Warranty

This one year limited warranty is extended to the original consumer purchaser of this Polaris Vac-Sweep 380 Automatic Pool Cleaner manufactured by Zodiac Pool Care, Inc., from date of manufacture of the unit as established by the serial number, or one year from date of purchase with proof of purchase, whichever is later. Zodiac warrants this product, including all parts and components thereof, to be free of defects in material and workmanship. Normal replacement items such as bags, tires, sweep hoses or sweep hose scrubbers which have been worn out by use or improper installation are not covered by this warranty. The Polaris 380 frame is warranted for a period of ten years.

This limited warranty does not apply if the failure is caused or contributed to by any of the following: improper handling, improper usage, improper storage, winter freezing, abuse, improper installation, removal of the in-filter screen, unsuitable application of the unit, improper maintenance, lack of reasonable and necessary maintenance, damage in transit or during installation, or damage from repairs/alterations made or attempted by anyone other than Zodiac or one of its Authorized Service Centers. In no event shall Zodiac be liable for incidental or consequential damages of any nature or for damages to persons or property, including damage to vinyl liners, plaster, tile, aggregate-based and other pool surfaces, or damages resulting from the use of this product with a substandard pool circulation system or chemical imbalance.

Authorization to return a unit or part to the plant of manufacture must be obtained from the Zodiac Customer Service Department. Check with your dealer for the local procedure before exercising this warranty. If further directions or instructions should be required, contact the Customer Service Department at 1-800-822-7933 (USA and Canada only) or (760) 599-9600. Be sure to insure the shipment against loss or damage in transit.

This limited warranty is valid only in the United States of America, Canada and Australia, and it does not apply to Polaris Vac-Sweep 380 Automatic Swimming Pool Cleaners sold or installed in any other country. Polaris Vac-Sweep 380 Automatic Pool Cleaners sold in the United Kingdom are warranted for a period of two years from date of invoicing to the first user.

WARNING: USE OF POLARIS 380 IN A VINYL LINER POOL

Certain vinyl liner patterns are particularly susceptible to rapid surface wear or pattern removal caused by objects coming into contact with the vinyl surface, including pool brushes, pool toys, floats, fountains, chlorine dispensers, and automatic pool cleaners. Some vinyl liner patterns can be seriously scratched or abraded simply by rubbing the surface with a pool brush. Ink from the pattern can also rub off during the installation process or when it comes into contact with objects in the pool. Zodiac is not responsible for, and the Limited Warranty does not cover, pattern removal, abrasion or markings on vinyl liners.

U.S. Patents: 6,908,550; 4,589,986; 4,558,479. Foreign Patents: 1,259,459; 1,259,509; 3,502,503; 2,153,208; 1,690,060; 85/0648. Unique product shape is a registered trademark.

Introduction

Congratulations on the purchase of your new automatic pool cleaner, and thank you for choosing Polaris. The Polaris Vac-Sweep® 380 is designed to give you years of dependable and efficient service.

Like most mechanical devices, it will require periodic adjustments, routine maintenance, and the replacement of certain hardworking parts. Please have your cleaner checked occasionally by your local Polaris dealer or authorized service center.

Always insist on genuine Polaris replacement parts. Non-Polaris parts are not made to our specifications. They may have an adverse effect on the operation of your Polaris or may even damage it.

For best results, the Polaris 380 should be installed by a pool professional. For those with experience and confidence in handling plumbing and mechanical equipment, installation is outlined in this manual.

Polaris 380 Complete Cleaner

- | | |
|-----------------------------|---|
| 1. All-Purpose Zippered Bag | 7. Hose Floats |
| 2. Head Float | 8. Back-up Valve |
| 3. Cleaner Body | 9. In-line Filter Assembly |
| 4. Sweep Hose | 10. Quick Disconnect with
Universal Wall Fitting (UWF) |
| 5. Sweep Hose Scrubber | 11. Restrictor Disks (one red and one blue) |
| 6. Feed Hose | |

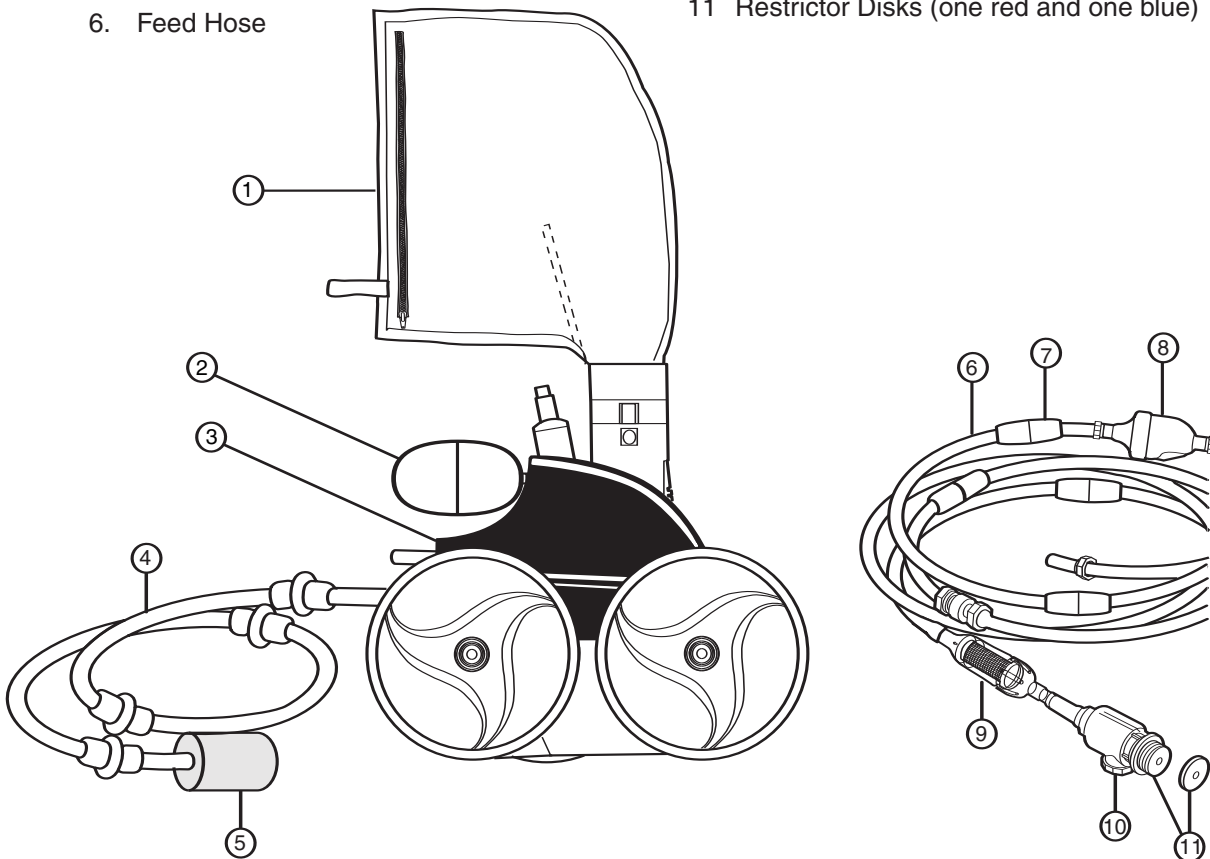

Quick Installation Instructions

1

Install the Universal Wall Fitting

Installs in minutes on pools with a dedicated cleaner return line and a threaded 1-1/2" female pipe fitting.

1. Turn on the filtration pump and flush out the plumbing line. Turn pump off.
2. Remove the UWF from the Quick Disconnect and screw the UWF with the blue restrictor disk into the return opening.
3. Turn the Quick Disconnect clockwise into the UWF and pull away to secure.

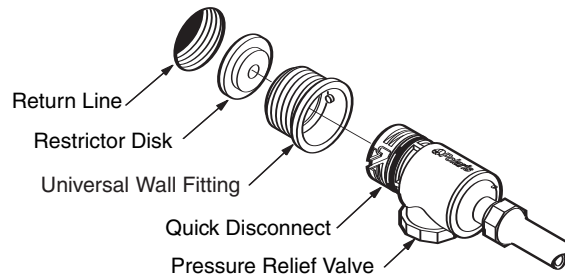

2

Adjust Feed Hose To Fit Pool Length

Measure the deepest part of the pool. Cut leader hose, from end that attaches to feed hose, so length is equal to the greatest depth of the pool.

Attach leader hose to feed hose and connect hose to the pool wall at the return line. Extend hose to farthest point of pool. The hose end must be within 6" – longer or shorter – of the farthest point. See dotted circle.

Hose too long? Separate hose at center swivel. Cut equal amounts of the overage from each 10-foot feed hose section.

Hose too short? Buy an additional feed hose section (part #9-100-3104), one swivel (part #D20) and two hose nuts (part #D15) from an authorized Polaris dealer.

After adjusting hose, position hose floats as shown.

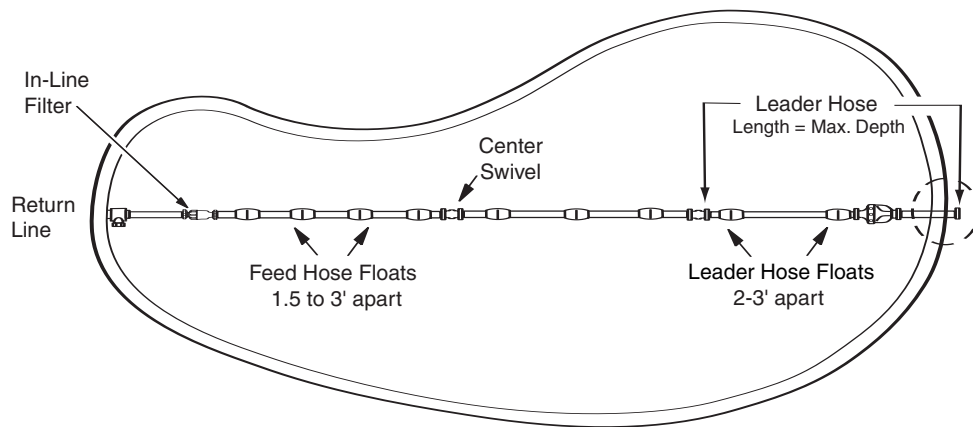

3

Assemble the Cleaner

1. Use the nut to attach the feed hose to the feed pipe.
2. Pull out the bag and attach the bag collar to the feed hose.
3. Push head float all the way in against the cleaner body.
4. Turn on the pool filtration pump and allow it to prime before turning on the booster pump.

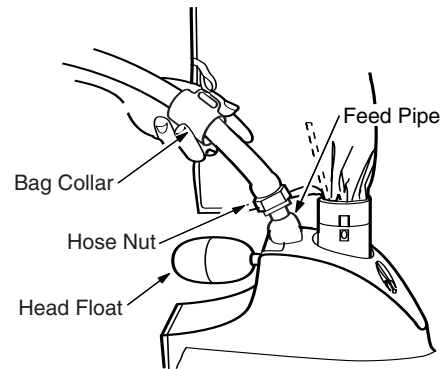

4

Check for Proper RPM

Before operating the Polaris, check for proper wheel revolutions per minute (RPM). For maximum efficiency, the Polaris should operate between 28 and 32 RPM.

1. Mark the single-wheel side tire.
2. Turn pump on, hold cleaner below water level and count wheel revolutions for one minute.

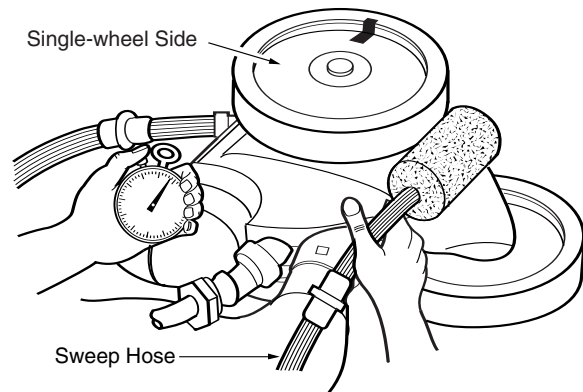

If count is **less than 28 RPM**:

- Check the filter screen in the in-line filter for debris that restricts water flow.
- Clean the skimmer, filter and pump basket, clearing debris that restricts water flow.
- Check the hoses, connections and swivels for leaks that cause loss of water pressure.
- Remove the blue restrictor disk from the UWF.
- If an adjustable valve is installed on the booster pump or cleaner line, open it completely so water can flow freely to the Polaris.

If count is **more than 32 RPM**:

- Replace the blue restrictor disk in the UWF with the red restrictor. If the flow is still too high, unscrew the pressure relief valve until the proper RPM is reached. Note: The pressure relief valve should only be adjusted when a restrictor is installed.
- If an adjustable valve is installed after the booster pump, adjust it to reduce the water flow to the cleaner.

Fine Tuning The Polaris Cleaner

When operating correctly, the Polaris 380 vacuums, sweeps and scrubs all surfaces randomly throughout the pool. Approximately every three minutes the Polaris 380 goes into back-up mode. This action pulls the Polaris away from pool obstacles and increases its random pattern.

Thrust Jet Adjustment

The thrust jet powers the direction of the Polaris. Factory position is eleven o'clock, but depending on the pool, other settings are helpful.

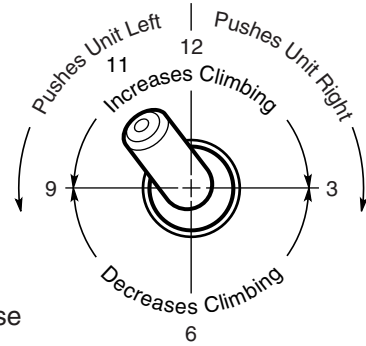

Sweep Hose Adjustment

The sweep hose should move in a gentle sweeping motion. To adjust, turn off the booster pump and turn the sweep hose adjustment screw. Turn clockwise to decrease the motion.

Routine Maintenance

Cleaning the Bag

Remove the bag collar from the feed hose and depress the prongs to release the bag from the cleaner. Open the bag closure and dump out the debris.

- Empty the filter bag when it is half full, especially if the dirt load is sand.
- It is easier to empty the filter bag when it is dry. Alternate between two bags.

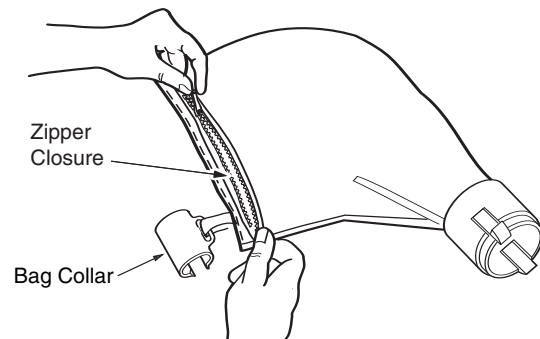

Cleaning the Filters

Always disconnect the Polaris before cleaning or backwashing the pool filter, and let the filtration system run for at least five minutes before reconnecting the cleaner.

To clean the in-line filter screen, pull it out of the filter assembly, rinse it and press it firmly back into place

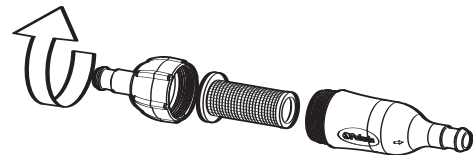

Storage and Winterizing

Never store the Polaris in direct sunlight. When storing for the winter, drain out all the water (freeze damage is not covered under the warranty). Remove the UWF from the pool wall by attaching the Quick Disconnect and using pulling pressure to unscrew. If necessary, use the UWF Removal Tool (part #10-102-00) available from any authorized Polaris dealer.

Polaris380

Exploded Parts Diagram

English

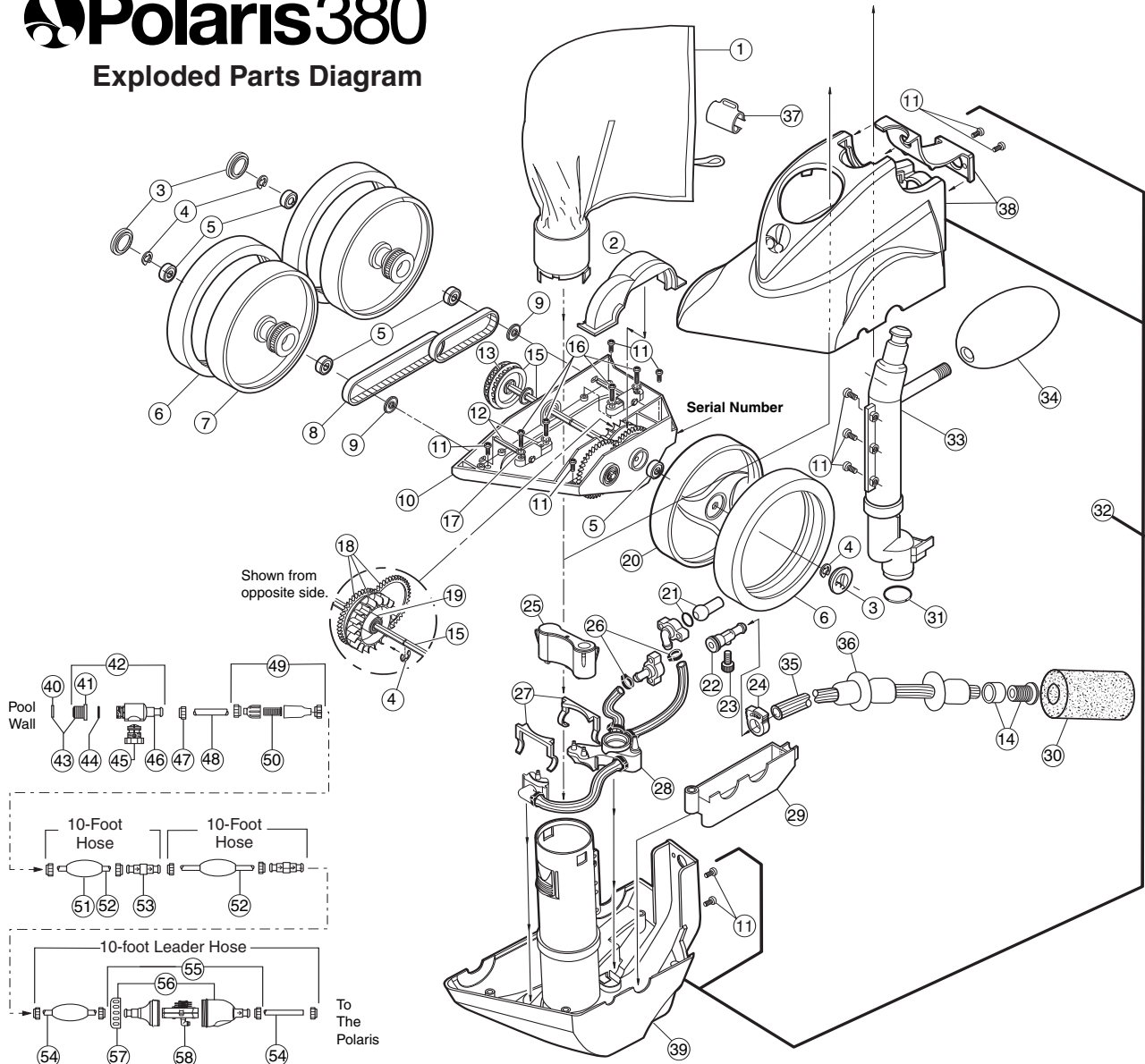

No.	Part	#Description	Qty	No.	Part	#Description	Qty	No.	Part	#Description	Qty
1	9-100-1021	All-Purpose Zippered Bag*	1	20	9-100-1116	Wheel, Single-side	1	40	10-112-00	Restrictor Disks. Red and Blue	2
2	9-100-1152	Housing, Turbine Upper	1	21	C131	Thrust Jet Kit	1	41	6-500-00	Universal Wall Fitting (UWF)	1
3	9-100-1114	Hub Cap	3	22	9-100-7008	Sweep Hose Barb Complete	1	42	9-100-9001	UWF Connector Assembly	1
4	9-100-5107	E-clip, Stainless Steel	10	23	B20	Adjustment Screw, Sweep Hose	1	43	10-108-00	UWF Restrictor Kit	1
5	9-100-1108	Ball Bearing	8	24	B15	Sweep Hose Attachment Clamp	1	44	6-505-00	O-Ring, UWF/QD	1
6	C10	Tire, MaxTrax®*	3	25	9-100-9004	Base Weight	1	45	9-100-9002	Pressure Relief Valve, Black	1
7	9-100-1008	Wheel, Double-side	2	26	9-100-7170	Hose Clamp for WMS	6	46	D29	Quick Disconnect, UWF	1
8	9-100-1017	Belt Kit, Small and Large	1	27	9-100-7009	Jet Retainer	2	47	D15	Hose Nut	10
9	9-100-7011	Shield, Bearing	3	28	9-100-7010	Water Management (WMS)	1	48	**	Adapter Hose, 8-1/2"	1
10	9-100-1005	Frame	1	29	9-100-1155	Housing, Turbine Lower	1	49	48-080	In-Line Filter Assembly	1
11	9-100-5125	Screw, 8-32 x 1/2" SS	11	30	9-100-3105	Sweep Hose Scrubber*	1	50	48-222	Screen, In-Line Filter	1
12	9-100-1139	Axle Block Kit, Front & Rear	1	31	9-100-5132	O-Ring, Feed Pipe	1	51	D10	Float, Feed Hose	9
13	9-100-1010	Belt Divider, Transfer Pulley	1	32	9-100-7030	Top and Base Assembly	1	52	D45	Feed Hose, 10 Ft	2
14	B25	Orifice Tip with Tip Guard	1	33	9-100-7003	Feed Pipe/Timer Blank Assy	1	53	D20	Swivel, Ball Bearing	2
15	9-100-1007	Trans Pulley/Drive Shaft Assy	1	34	A20	Float, Head	1	54	D50	Feed Hose, Leader, 10 Ft	1
16	9-100-5115	Screw, 8-32 x 3/4" SS	4	35	B5	Sweep Hose Complete*	1	55	G52	Back-up Valve Kit	1
17	9-100-5130	Lock Washer, Axle Block	4	36	B10	Wear Rings*	8	56	G54	Case Kit for G52	1
18	9-100-1132	Drive Train Gear Kit with Turbine Bearing	1	37	9-100-1018	Bag Collar	1	57	G57	Collar, Back-up Valve	1
19	9-100-1103	Turbine Wheel with Bearing	1	38	9-100-1240	Top Housing	1	58	G53	Mechanism for G52	1
					9-100-7026	Base Assembly	1				

*Wear items not covered by warranty.

Troubleshooting

If the Polaris cleaner displays the following actions, adjustments may be necessary to restore performance. Refer to exploded parts diagram for part references.

Action: Cleaner hangs up on steps or other obstacles for longer than 3 minutes.

- Solution:
1. Check the wheel RPM.
 2. Verify the back-up valve is cycling.
 3. Adjust the thrust jet.
 4. Remove unnecessary pool hardware or install a Ladder Guard Kit (order part #G21 from a Polaris dealer).

Action: Polaris is sluggish, running with less power than normal.

- Solution:
1. Check the filter screen in the in-line filter and clean, if necessary.
 2. Clean the skimmer basket, pump basket, and pool filter.
 3. Check all of the hoses, connections, and swivels for leaks that could cause loss of water pressure.
 4. Check the wheel RPM.

Action: Polaris flies around the pool and/or does not make contact with the bottom.

- Solution:
1. Confirm that the blue restrictor disk is installed in the UWF to decrease water flow. Or, install the red restrictor disk to decrease water flow even more.
 2. Check the wheel RPM. If more than 32 RPM, unscrew the pressure relief valve to decrease water flow to cleaner. Note: The pressure relief valve should only be adjusted when a restrictor is installed.

3. Verify the back-up valve is cycling. Hold the valve out of the water and watch the jet. It should come on and go off.

Action: Polaris does not back up.

- Solution:
1. Verify the back-up valve is cycling.
 2. Check the wheel RPM.
 3. If the bag is full, empty it.
 4. If head float has water in it, replace it.
 5. Make sure feed hose is floating.

Action: Polaris only turns in one direction.

- Solution:
1. Adjust the thrust jet.
 2. Make sure feed hose is floating.

Action: Feed hose becomes tangled.

- Solution:
1. Remeasure the hose to verify that it is adjusted to the proper length for the pool shape.
 2. With the Polaris operating, check that the swivels in the hose and the hose connections turn freely.
 3. Make sure feed hose is floating.
 4. With the Polaris turned off, spin each of the wheels. All wheels should turn together.

Action: Sweep hose is sucked into the vacuum tube.

- Solution:
1. Make sure the opening at the end of the sweep hose is not blocked by the sweep hose scrubber.
 2. Adjust the sweep hose to a gentle sweeping motion.

Action: Sweep hose sprays too much water out of the pool.

- Solution:
1. Adjust the speed of the sweep hose by tightening the adjustment screw.
 2. Replace the sweep hose scrubber if it is worn or missing.
 3. Add a sweep hose weight (order part #B2) to keep the sweep hose from spraying.

Action: The cleaner does not clean the entire pool.

- Solution:
1. Check the hose length reaches within 6" of the farthest point of the pool. If not, order a new hose section from your Polaris dealer.
 2. Check thrust jet for 11:00 position that optimizes random turning.
 3. While the cleaner is operating, hold it upside down and look into the vacuum tube. There should be three distinct, even jets of water. If there are not, contact Customer Service or a Polaris authorized Service Center for assistance.

Action: The cleaner is running in circles on its side.

- Solution:
1. Check filter bag, if full it can weigh the cleaner down on one side.
 2. Remove the head float and shake it. If there is water in the float, order a new one.
 3. Check the hose floats to make sure they are spaced evenly.

Troubleshooting Worksheet

If these solutions do not result in improved performance, contact the Polaris dealer who sold you the cleaner or call Customer Service.

In order to provide faster and more convenient service, please have the following information available at the time of your call or when taking the Polaris in for service.

1. Serial #: _____
2. Wheel RPM: _____
3. Is the back-up valve cycling?
 Yes No
4. Is the feed hose the proper length?
 Yes No
5. Are the swivels rotating freely?
 Yes No
6. How often do you clean the filter screen in the in-line filter?
 Never Once a Week
 Twice a Week Once a Month
7. Are the vacuum jets obstructed?
(While the cleaner is operating, hold it upside down and look into the vacuum tube. There should be three distinct, even jets of water.)
 Yes No
8. Is the drive train functioning?
(As you spin each wheel independently, all the wheels should spin.)
 Yes No



2620 Commerce Way, Vista, CA 92081-8438 • 760-599-9600 • 1-800-822-7933

www.polarispool.com